

ET Series

變壓器係根據客戶提供的規格書及bobbin的結構設計。
Transformer is based on a customers' specifications, demand and construction of bobbin to set up.

How To Order

HG103 ET28 - □ □ □ □

材質 規格 Code
Material Core Size

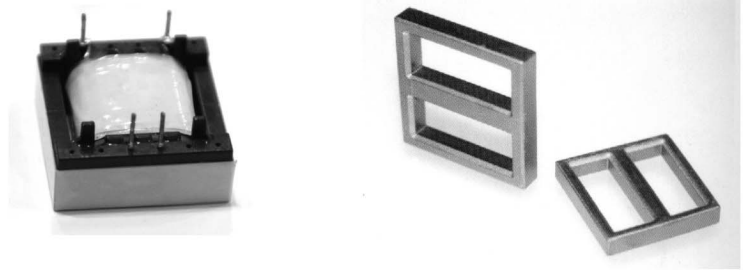

Construction of Bobbin

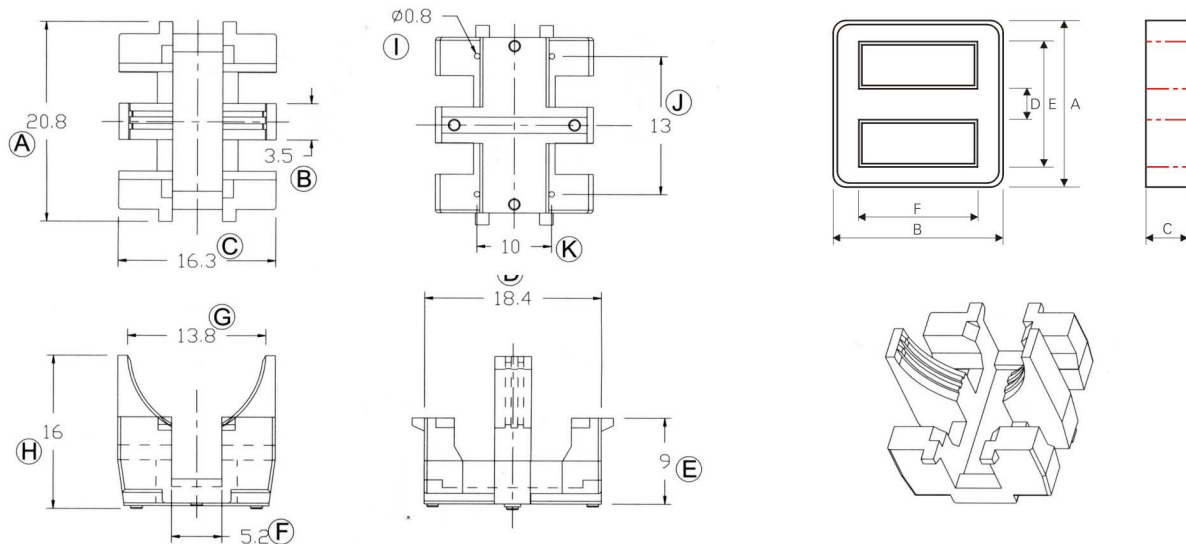

規格 Core size	尺寸 Dimensions(mm)						有效參數 Effective parameters			
	A	B	C	D	E(min)	F(min)	C1 (mm ⁻¹)	Ae (mm ²)	Le (mm)	Ve (mm ³)
ET20	20.1±0.4	20.1±0.4	4.4±0.2	4.0±0.2	15.7	15.7	2.96	17.6	52.1	917.0
ET24	24.2±0.4	24.2±0.4	4.0±0.3	4.0±0.3	19.0	19.0	3.31	18.0	60.0	1098
ET25	25.5±0.5	25.5±0.5	5.0±0.3	5.0±0.3	19.2	19.2	2.3	27.6	62.3	1721
ET28	28.4±0.5	28.4±0.5	5.0±0.3	5.0±0.3	22.2	22.2	2.54	27.0	70.0	1972
ET35	35.5±0.6	35.5±0.6	7.5±0.4	7.5±0.3	26.5	26.5	1.46	58.3	85.2	4970

規格 Core size	電感因數 AL(nH/N ²) ± 25%					
	HG302	HG502 HS502	HG702 HS702	HG103 HS103	HG123	HG153
ET20		2200	3100	4400	5500	7350
ET24			2600	3600	4500	6000
ET25			3200	3800	4750	6200
ET28		2700	3600	4800	6000	8000
ET35			6000	8400	10500	14000